

深圳市晶彩世界科技有限公司

产品规格书

Product Type: 12.1" TFT LCD Module

LCD Interface: 20PIN LVDS

Luminance: 600 cd/m²

Module No: HSD121KXN1-A10-2JF

CUSTOMER APPROVED	PREPARE BY	CHECK BY	APPROVED BY
SUPPLIER APPROVED	PREPARE BY	CHECK BY	APPROVED BY

深圳市晶彩世界科技有限公司

Document Title		Page No.	3 / 24
Document No.		Revision	2.0

Contents

1.0	General description	p.4
2.0	Absolute maximum ratings.....	p.5
3.0	Optical characteristics.....	p.6
4.0	Block diagram	p.10
5.0	Interface pin connection	p.12
6.0	Electrical characteristics	p.14
7.0	Reliability test items	p.19
8.0	Outline dimension	p.20
9.0	Lot mark	p.22
10.0	Package specification	p.23
11.0	General precaution	p.24

深圳市晶彩世界科技有限公司

Document Title		Page No.	4 / 24
Document No.		Revision	2.0

1.0 GENERAL DESCRIPTION

1.1 Introduction

HannStar Display model HSD121KXN1-A10-2JF is a color active matrix thin film transistor (TFT) liquid crystal display (LCD) that uses amorphous silicon TFT as a switching device. This model is composed of a TFT LCD panel, a driving circuit and a back light system. This TFT LCD has a 12.1 inch diagonally measured active display area with XGA (1024 horizontal by 768 vertical pixel) resolution.

1.2 Features

- 12.1 (4:3 diagonal) inch configuration
- 16.7M
- ROHS / Halogen Free Compliance

1.3 Applications

- Automobile

1.4 General information

Item	Specification	Unit	
Outline Dimension	260.5 (H) x 204 (V) x 8.6 (D) (Typ)	mm	
Display area	245.76(H)x184.32(V) (12.1" diagonal)	mm	
Number of Pixel	1024(H) x 768(V)	pixels	
Pixel pitch	0.2400(H) x 0.2400(V)	mm	
Pixel arrangement	RGB Vertical Stripe		
Display mode	Normally Black		
NTSC	70(Typ.)	%	
Surface treatment	Antiglare, Hard-Coating (3H)		
Weight	520(Max.)	g	
Back-light	Single LED (Side-Light type)		
Power Consumption	Logic System (White Pattern)	Logic 0.8W(typ) 1.2W(max)	W
	B/L System	10.8W(max.)	W

1.5 Mechanical Information

Item	Min.	Typ.	Max.	Unit	
Module Size	Horizontal (H)	260.0	260.5	261.0	mm
	Vertical (V)	203.5	204	204.5	mm
	Depth (D)	8.3	8.6	8.9	mm
Weight	—	500	520	g	

深圳市晶彩世界科技有限公司

Document Title		Page No.	5 / 24
Document No.		Revision	2.0

2.0 ABSOLUTE MAXIMUM RATINGS

2.1 Electrical Absolute Rating

2.1.1 TFT LCD Module

Item	Symbol	Min.	Max.	Unit	Note
Logic supply voltage	V_{DD}	-0.3	5.0	V	
Back-light supply voltage	V_i	-0.3	28.0	V	

2.2 Environment Absolute Rating

Item	Symbol	Min.	Max.	Unit	Note
Operating Temperature	T_{opa}	-20	70	°C	
Storage Temperature	T_{stg}	-30	85	°C	

深圳市晶彩世界科技有限公司

Document Title		Page No.	6 / 24
Document No.		Revision	2.0

3.0 OPTICAL CHARACTERISTICS

3.1 Optical specification

Item		Symbol	Condition	Min.	Typ.	Max.	Unit	Note	
Contrast		CR	$\Theta=0$ Normal viewing angle	600	900	—		(1)(2)	
Response time	Rising	TR+TF		—	30	40	msec	(1)(3)	
	Falling								
White luminance (Center)		Y_L			500	600	—	cd/m ²	(1)(4) ($I_L=240mA$)
Color chromaticity (CIE1931)	White	W_x			0.251	0.291	0.331		(1)(4)
		W_y			0.288	0.328	0.368		
	Red	R_x			0.613	0.653	0.703		
		R_y			0.302	0.342	0.382		
	Green	G_x			0.264	0.304	0.344		
		G_y			0.581	0.621	0.661		
	Blue	B_x		0.104	0.144	0.184			
		B_y		0.054	0.094	0.134			
Viewing angle	Hor.	Θ_L	CR>10	80	85	—			
		Θ_R		80	85	—			
	Ver.	Θ_U		80	85	—			
		Θ_D		80	85	—			
Brightness uniformity		B_{UNI}	$\Theta=0$	70	80	—	%	(5)	
Optima View Direction		Free						(6)	

3.2 Measuring Condition

- Measuring surrounding : dark room
- LED current I_L : 240mA
- Ambient temperature : $25\pm 2^\circ C$
- 15min. warm-up time.

深圳市晶彩世界科技有限公司

Document Title		Page No.	7 / 24
Document No.		Revision	2.0

3.3 Measuring Equipment

■ FPM520 of Westar Display technologies, INC., which utilized SR-3 for Chromaticity and BM-5A for other optical characteristics.

■ Measuring spot size : 20 ~ 21 mm

Note (1) Definition of Viewing Angle:

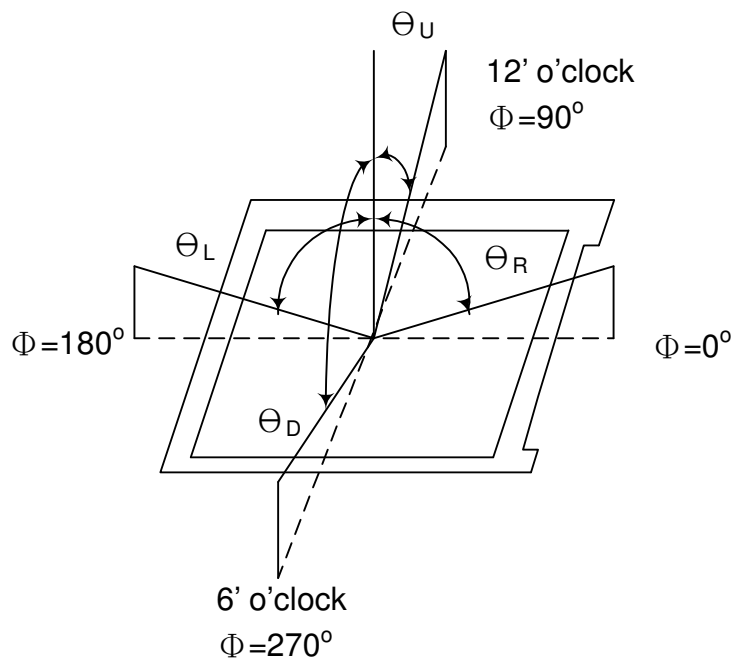

Note (2) Definition of Contrast Ratio (CR) :
measured at the center point of panel

$$CR = \frac{\text{Luminance with all pixels white}}{\text{Luminance with all pixels black}}$$

深圳市晶彩世界科技有限公司

Document Title		Page No.	8 / 24
Document No.		Revision	2.0

Note (3) Definition of Response Time : Sum of T_R and T_F

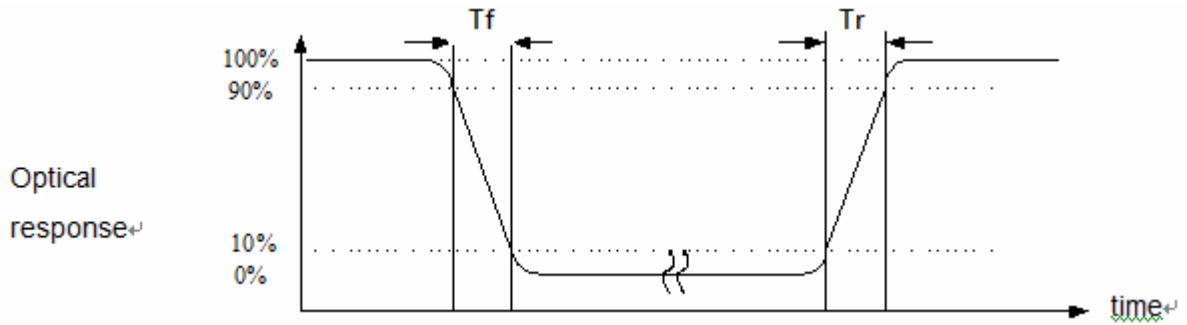

Note (4) Definition of optical measurement setup

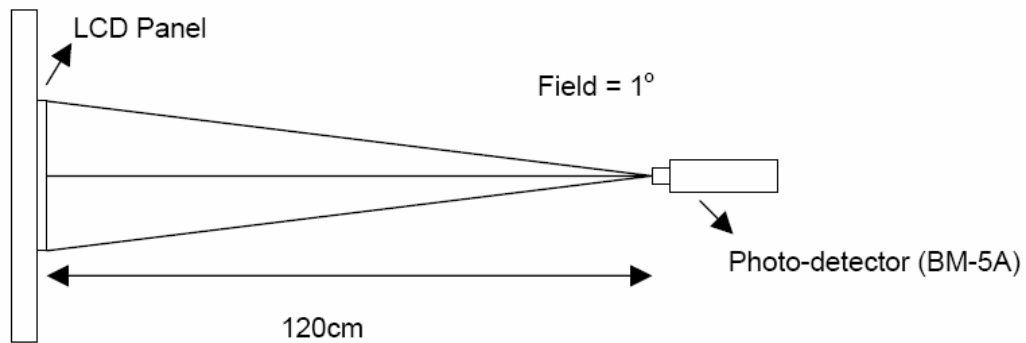

深圳市晶彩世界科技有限公司

Document Title		Page No.	9 / 24
Document No.		Revision	2.0

Note (5) Definition of brightness uniformity

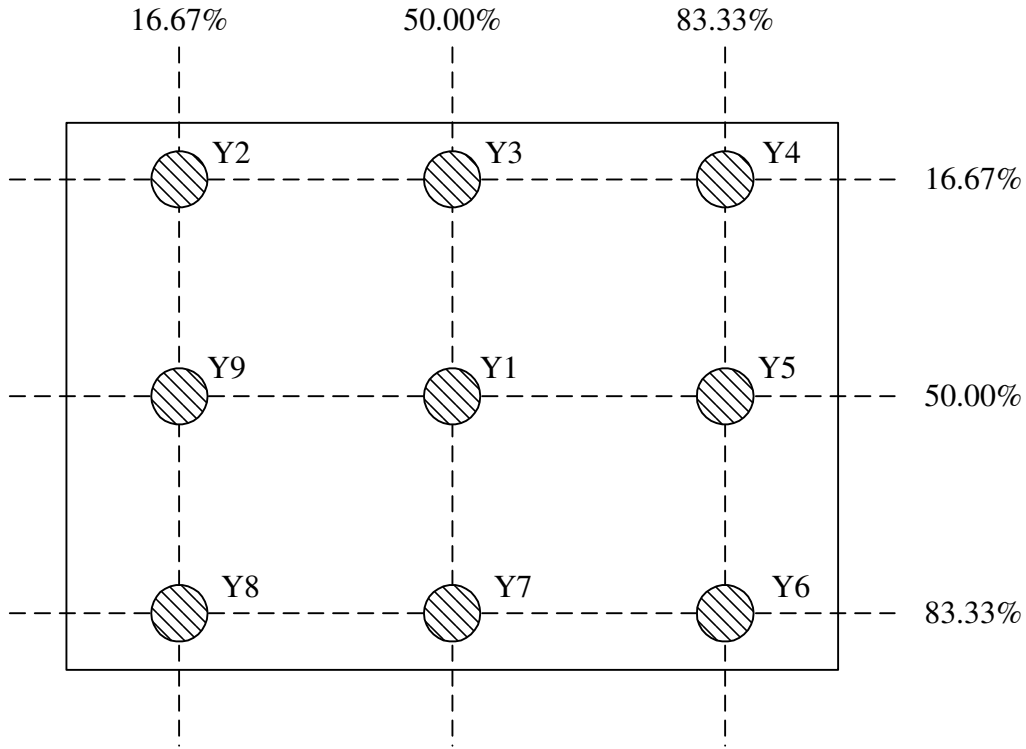

$$\text{Luminance uniformity} = \frac{(\text{Min Luminance of 9 points})}{(\text{Max Luminance of 9 points})} \times 100\%$$

Note (6) : Rubbing Direction (The different Rubbing Direction will cause the different optima view direction.)

深圳市晶彩世界科技有限公司

Document Title		Page No.	10 / 24
Document No.		Revision	2.0

4.0 BLOCK DIAGRAM

4.1 TFT LCD Module:

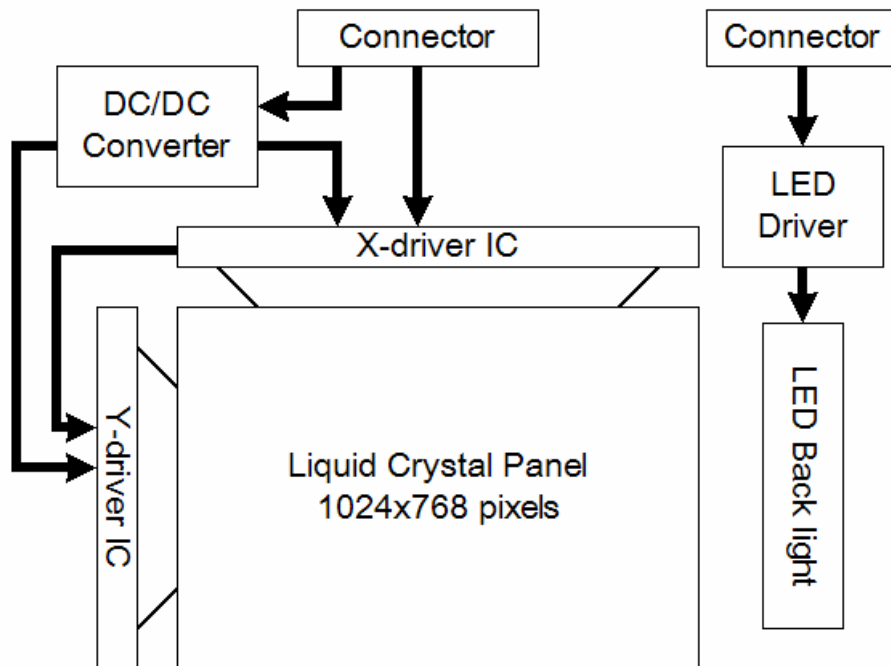

4.2 Pixel Format

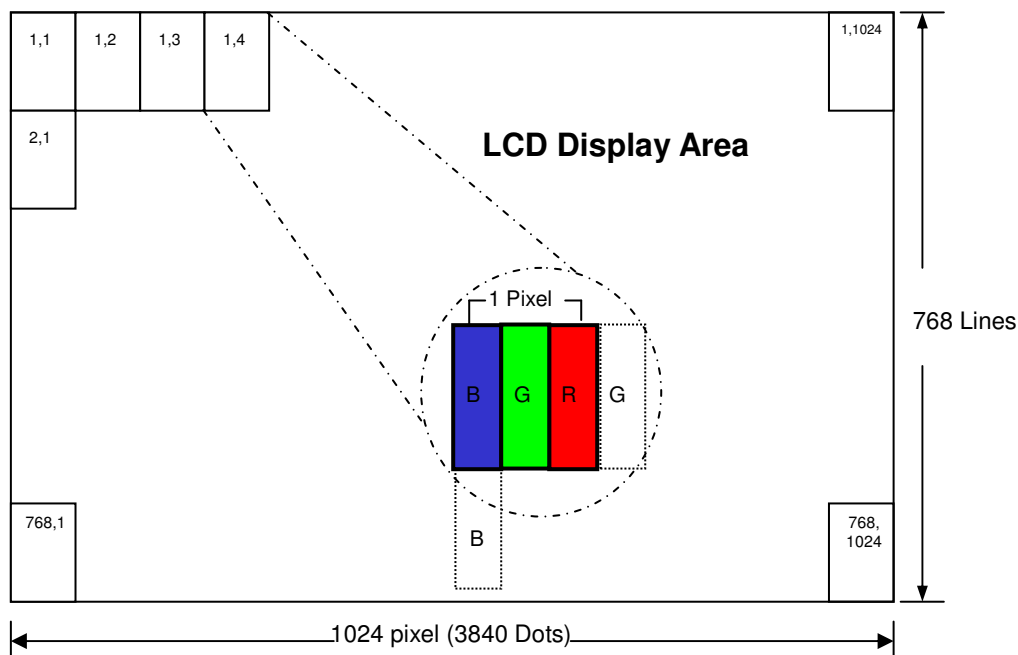

深圳市晶彩世界科技有限公司

Document Title		Page No.	12 / 24
Document No.		Revision	2.0

5.0 INTERFACE PIN CONNECTION

5.1 LCM connector pin assignment (CN1) : STARCONN 076B20-0048RA-G4 or JAE FI-SEB20P-HFE (or equivalent)

Pin NO.	Symbol	Description	Note
1	RX3+	Differential Data Input, CH3 (Positive)	
2	RX3-	Differential Data Input, CH3 (Negative)	
3	BIST	Normal operation/BIST pattern select. BIST="1" : BIST mode. BIST="0" : Normal operation.	Note*
4	SEL68	6bit/8bit mode select, SELB = "1" : LVDS input data is 8bits SELB = "0" : LVDS input data is 6bits	Note*
5	GND	Ground	
6	RXC+	Differential Clock Input (Positive)	
7	RXC-	Differential Clock Input (Negative)	
8	GND	Ground	
9	RX2+	Differential Data Input , CH2 (Positive)	
10	RX2-	Differential Data Input , CH2 (Negative)	
11	GND	Ground	
12	RX1+	Differential Data Input , CH1 (Positive)	
13	RX1-	Differential Data Input, CH1 (Negative)	
14	GND	Ground	
15	RX0+	Differential Data Input, CH0 (Positive)	
16	RX0-	Differential Data Input, CH0 (Negative)	
17	reLR	Left or right display control SHLR="1" : Right → Left SHLR="0" :Left → Right	Note*
18	reUD	Up / down display control UPDN="1" : Down → Up UPDN="0" : Up → Down	Note*
19	VDD	Power supply, 3.3V	
20	VDD	Power supply, 3.3V	

Note* : The high level voltage "1" is 3.3V, and the low level voltage "0" is GND.

深圳市晶彩世界科技有限公司

Document Title		Page No.	13 / 24
Document No.		Revision	2.0

Note 1 : UPDN and SHLR control function

reLR	reUD	Data shifting
0	0	Left→Right, Up→Down
1	0	Right→Left, Up→Down
0	1	Left→Right, Down→Up
1	1	Right→Left, Down→Up

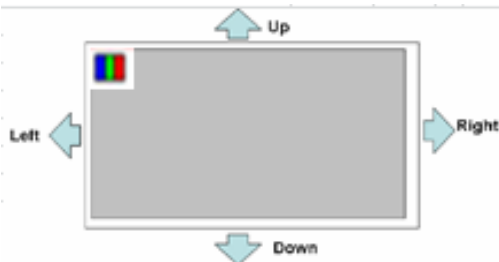

5.2 Backlight Pin Assignment (CN2) : ACES 91208-01001-H01 (or equivalent)

Pin NO.	Symbol	Description	Note
1	Vi	Converter input voltage	12V
2	Vi	Converter input voltage	12V
3	Vi	Converter input voltage	12V
4	Vi	Converter input voltage	12V
5	VGND	Converter ground	Ground
6	VGND	Converter ground	Ground
7	VGND	Converter ground	Ground
8	VGND	Converter ground	Ground
9	EN	Enable pin	3.3V
10	ADJ	Backlight Adjust	PWM Dimming (100Hz-30KHz, Hi: 2.0~3.3V,Lo : 0~0.8V)

深圳市晶彩世界科技有限公司

Document Title		Page No.	14 / 24
Document No.		Revision	2.0

6.0 ELECTRICAL CHARACTERISTICS

6.1 TFT LCD Module

Item	Symbol	Min.	Typ.	Max.	Unit	Note
Supply Voltage	V_{DD}	3.0	3.3	3.6	V	
Current of power supply	I_{DD}	—	0.25	—	A	$V_{DD} = 3.3V$ 、white pattern (L255)
VDD Power	P_{DD}	—	0.8	1.2	W	$V_{DD} = 3.3V$ 、white pattern (L255)
Inrush current	I_{RUSH}	—	—	2.0	A	Note*

Note* : Inrush current test circuit and rising time setting (power on)

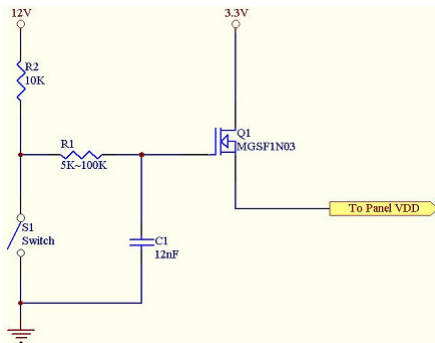

Test circuit

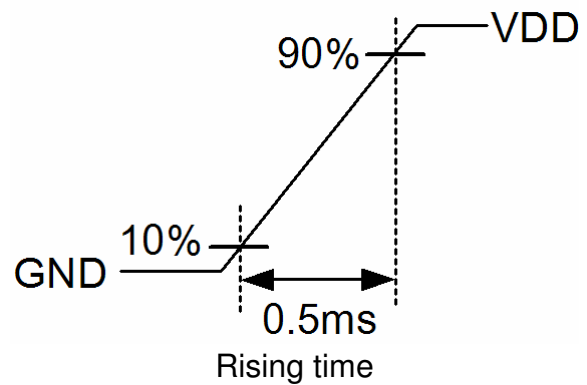

6.2 Switching Characteristics for LVDS Receiver

Item	Symbol	Min.	Typ.	Max.	Unit	Conditions
Differential Input High Threshold	V_{TH}	100	-	300	mV	
Differential Input Low Threshold	V_{TL}	-300	-	100	mV	
Differential input common mode voltage	V_{CM}	1.0	1.2	$1.7 - \frac{ V_{ID} }{2}$	V	
Input Current	I_{IN}	-10	-	10	μA	RX+/-, RXC+/-
Differential input Voltage	$ V_{ID} $	200	-	600	mV	

深圳市晶彩世界科技有限公司

Document Title		Page No.	15 / 24
Document No.		Revision	2.0

6.3 Bit LVDS input

6.3.1 6bit LVDS input

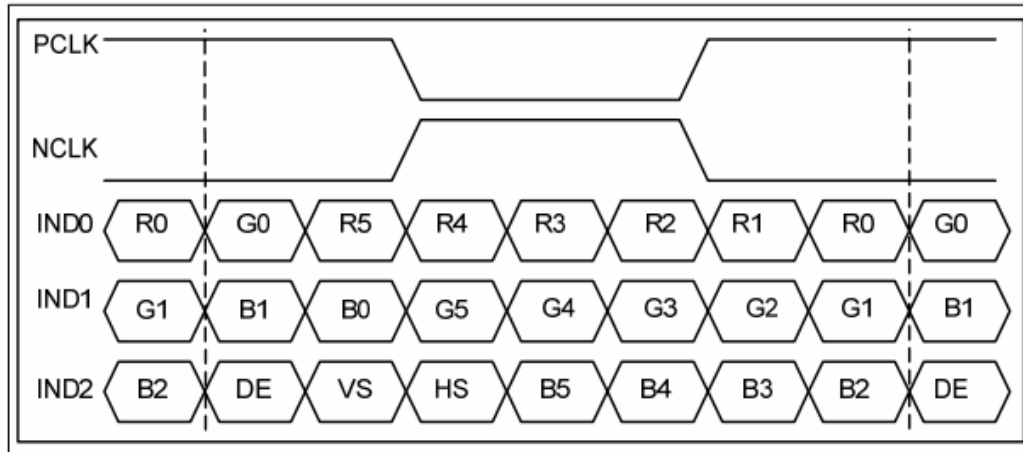

6.3.2 8Bit LVDS input

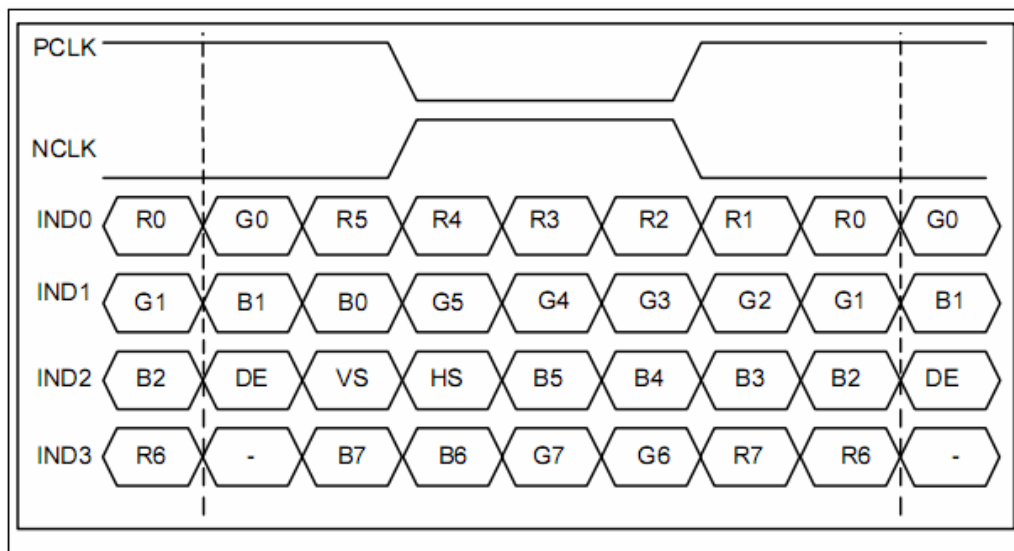

深圳市晶彩世界科技有限公司

Document Title		Page No.	16 / 24
Document No.		Revision	2.0

6.4 Interface Timing (DE mode)

Item	Symbol	Min.	Typ.	Max.	Unit
Frame Rate	--	59.95	60.05	60.15	Hz
Vertical Total Time	T_v	774	776	778	line
Vertical Display Time	T_{VD}	768			line
Vertical Blanking Time	T_{VB}	6	8	10	line
Horizontal Total Time	T_H	1084	1088	1092	clock
Horizontal Display Time	T_{HD}	1024			clock
Horizontal Blanking Time	T_{HB}	60	64	68	clock
Clock Rate	$1/T_{Clock}$	50.3	50.7	51.1	MHz

Timing Diagram of Interface Signal (DE mode)

1. Vertical

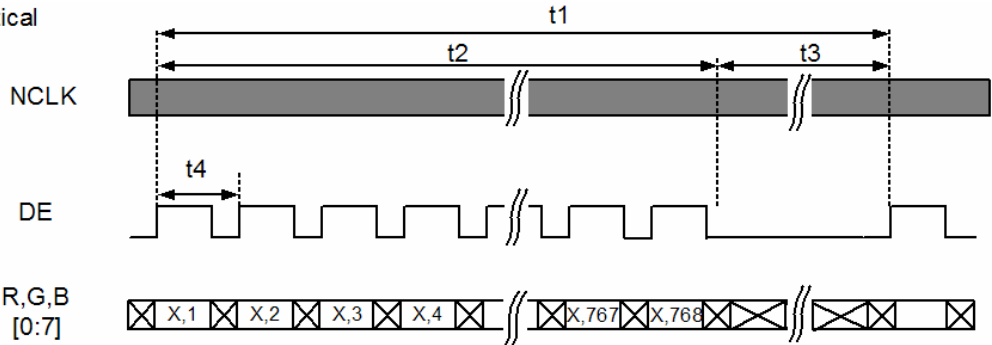

2. Horizontal

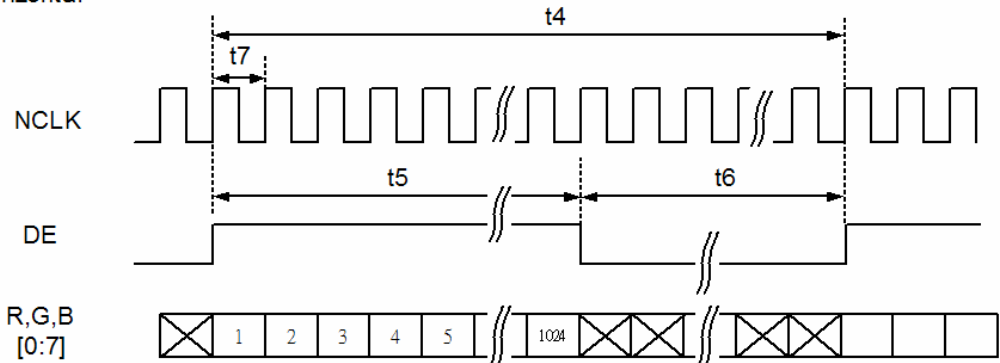

深圳市晶彩世界科技有限公司

Document Title		Page No.	17 / 24
Document No.		Revision	2.0

6.5 Power On / Off Sequence

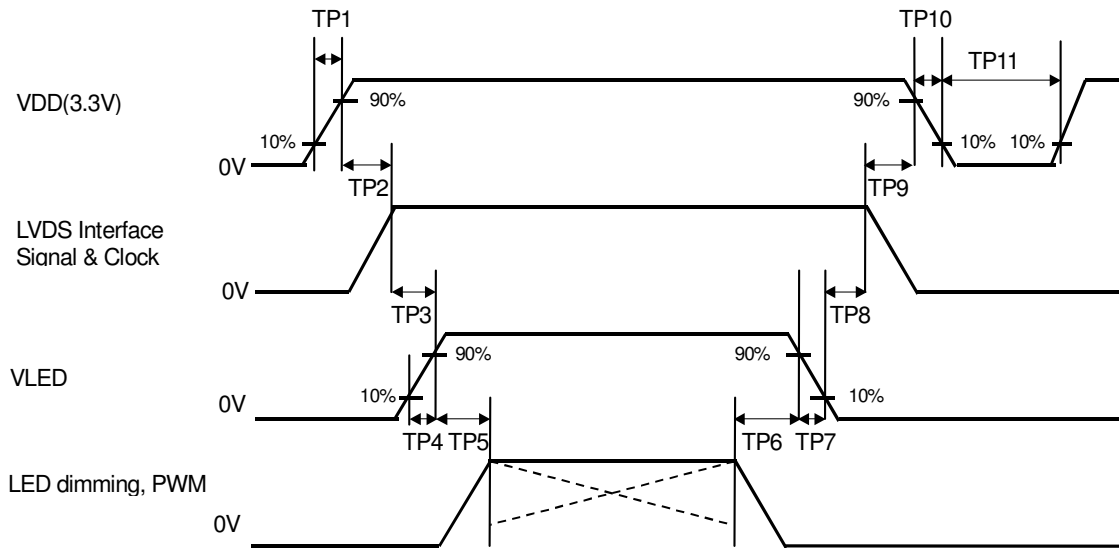

Item	Min.	Typ.	Max.	Unit
TP1	0.5	--	10	msec
TP2	0	--	50	msec
TP3	200	--	--	msec
TP4	0.5	--	10	msec
TP5	10	--	--	msec
TP6	10	--	--	msec
TP7	0	--	10	msec
TP8	200	--	--	msec
TP9	0	--	50	msec
TP10	1	--	10	msec
TP11	1000	--	--	msec

深圳市晶彩世界科技有限公司

Document Title		Page No.	18 / 24
Document No.		Revision	2.0

6.6 Backlight Unit

Parameter	Symbol	Min	Typ	Max	Units	Condition
Input Current	I_i	--	240		mA	$T_a=25^\circ\text{C}$
Input Voltage	V_i	33	35	37	Volt	$T_a=25^\circ\text{C}$
LED Life-Time	N/A	30,000	--	--	Hour	$T_a=25^\circ\text{C}$ $I_F=60\text{mA}$ Note (2)

6.7 Backlight DC Electrical Characteristics

Parameter	Symbol	Min	Typ	Max	Units	Note
Backlight Power Supply	V_i	10	12	16	Volt.	
LED_EN High Threshold	V_{ENH}	1.4	3.3	5.0	Volt.	
LED_EN Low Threshold	V_{ENL}	0	--	0.8	Volt.	
PWM High Threshold	V_{PWMH}	2.0	3.3	6.0	Volt.	
PWM Low Threshold	V_{PWML}	0	--	0.8	Volt.	
PWM Frequency	F_{PWM}	100	--	30K	Hz	Note (4)
PWM Duty Cycle	T_D	10	--	100	%	

Note (1) LED life time (Hr) can be defined as the time in which it continues to operate under the condition: $T_a=25\pm 3^\circ\text{C}$, typical IL value indicated in the above table until the brightness becomes less than 50%.

Note (2) The "LED life time" is defined as the module brightness decrease to 50% original brightness at $T_a=25^\circ\text{C}$ and $I_i=850\text{mA}$, the LED lifetime could be decreased if operating IL is larger than 850mA. The constant current driving method is suggested.

Note (3) LED Light Bar Circuit

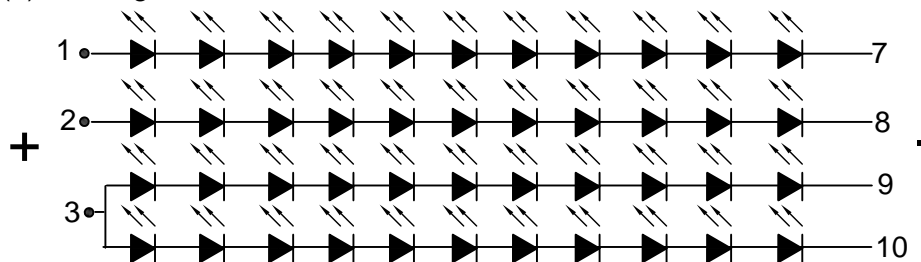

Note (4) Dimming controller waveform

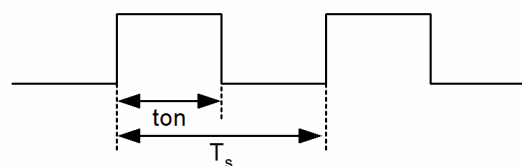

$$T_D = ton \div T_s \times 100\%$$

$$F_{PWM} = 1 \div T_s$$

深圳市晶彩世界科技有限公司

Document Title		Page No.	19 / 24
Document No.		Revision	2.0

7.0 Reliability test items

No.	Item	Conditions	Remark
1	High Temperature Storage	Ta=+85°C, 240hrs	
2	Low Temperature Storage	Ta=-30°C, 240hrs	
3	High Temperature Operation	Ta=+70°C, 240hrs	
4	Low Temperature Operation	Ta=-20°C, 240hrs	
5	High Temperature and High Humidity (operation)	Ta=+65°C, 90%RH, 240hrs	
6	Thermal Cycling Test (non operation)	-30°C(30min) → +85°C(30min), 500 cycles	
7	Electrostatic Discharge	±200V,200pF(0Ω) 1 time/connector	
8	Vibration	1.Random: 1.04G, 5~500Hz, XYZ, 30min/each direction 2.Sine: Freq.1.5G, 8~33.3Hz, Stoke: 1.3mm Sweep: 2.9G, 33.3~400Hz X/Z: 2hrs, Y: 4hrs	
9	Shock	Half-Sine, 100G, 6ms, ±XYZ, 3time	
10	Vibration (with carton)	Random: 0.015G ² /Hz, 5~200Hz -6dB/Octave, 200~400Hz XYZ 各方向 2hrs	
11	Drop (with carton)	Drop height condition, basis on the product weight and follow QB100-0027 1 corner, 3 edges, 6 surfaces	

Note: There is no display function NG issue occurred, all the cosmetic specification is judged before the reliability stress.

深圳市晶彩世界科技有限公司

Document Title		Page No.	21 / 24
Document No.		Revision	2.0

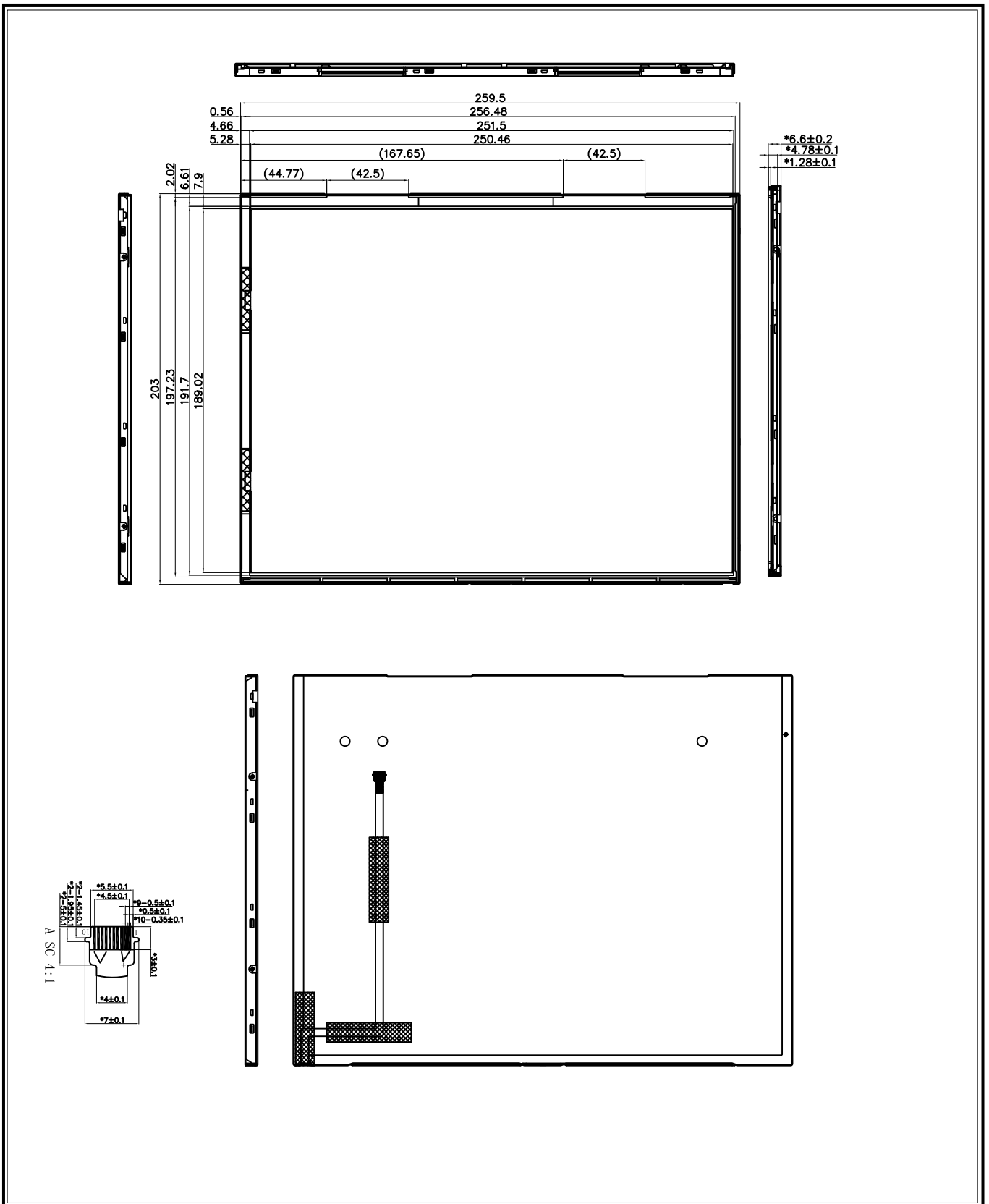

The information contained in this document is the exclusive property of HannStar Display Corporation. It shall not be disclosed, distributed or reproduced in whole or in part without written permission of HannStar Display Corporation.

Document Title	121KXN1-A10 Preliminary Specification for 路必康	Page No.	22 / 24
Document No.		Revision	2.0

10.0 PACKAGE SPECIFICATION

10.1 Packing form

LCM Model	Qty. in the Box	Inner Box Size(mm)	Notice
HSD121KXN1-A 00	20 pcs/Box	Ref. 360 x 345 x 285 ^H	--

10.2 Packing assembly drawings

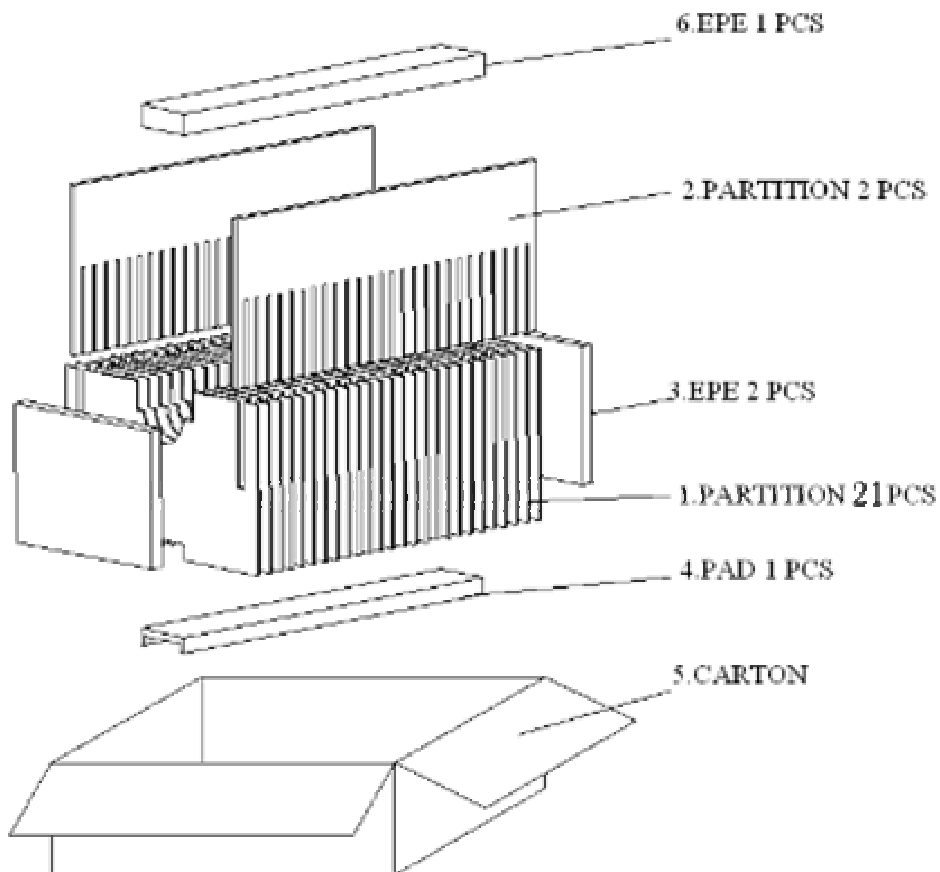

Document Title	121KXN1-A10 Preliminary Specification for 路必康	Page No.	23 / 24
Document No.		Revision	2.0

11.0 GENERAL PRECAUTION

11.1 Use Restriction

This product is not authorized for use in life supporting systems, aircraft navigation control systems, military systems and any other application where performance failure could be life-threatening or otherwise catastrophic.

11.2 Disassembling or Modification

Do not disassemble or modify the module. It may damage sensitive parts inside LCD module, and may cause scratches or dust on the display. HannStar does not warrant the module, if customers disassemble or modify the module.

11.3 Breakage of LCD Panel

11.3.1. If LCD panel is broken and liquid crystal spills out, do not ingest or inhale liquid crystal, and do not contact liquid crystal with skin.

11.3.2. If liquid crystal contacts mouth or eyes, rinse out with water immediately.

11.3.3. If liquid crystal contacts skin or cloths, wash it off immediately with alcohol and rinse thoroughly with water.

11.3.4. Handle carefully with chips of glass that may cause injury, when the glass is broken.

11.4 Electric Shock

11.4.1. Disconnect power supply before handling LCD module.

11.4.2. Do not pull or fold the LED cable.

11.4.3. Do not touch the parts inside LCD modules and the fluorescent LED's connector or cables in order to prevent electric shock.

11.5 Absolute Maximum Ratings and Power Protection Circuit

11.5.1. Do not exceed the absolute maximum rating values, such as the supply voltage variation, input voltage variation, variation in parts' parameters, environmental temperature, etc., otherwise LCD module may be damaged.

11.5.2. Please do not leave LCD module in the environment of high humidity and high temperature for a long time.

11.5.3. It's recommended to employ protection circuit for power supply.

11.6 Operation

11.6.1 Do not touch, push or rub the polarizer with anything harder than HB pencil lead.

11.6.2 Use fingerstalls of soft gloves in order to keep clean display quality, when persons handle the LCD module for incoming inspection or assembly.

11.6.3 When the surface is dusty, please wipe gently with absorbent cotton or other soft material.

Document Title	121KXN1-A10 Preliminary Specification for 路必康	Page No.	24 / 24
Document No.		Revision	2.0

11.6.4 Wipe off saliva or water drops as soon as possible. If saliva or water drops contact with polarizer for a long time, they may causes deformation or color fading.

11.6.5 When cleaning the adhesives, please use absorbent cotton wetted with a little petroleum benzine or other adequate solvent.

11.7 Mechanism

Please mount LCD module by using mounting holes arranged in four corners tightly.

11.8 Static Electricity

11.8.1 Protection film must remove very slowly from the surface of LCD module to prevent from electrostatic occurrence.

11.8.2 Because LCD module use CMOS-IC on circuit board and TFT-LCD panel, it is very weak to electrostatic discharge. Please be careful with electrostatic discharge. Persons who handle the module should be grounded through adequate methods.

11.9 Strong Light Exposure

The module shall not be exposed under strong light such as direct sunlight. Otherwise, display characteristics may be changed.

11.10 Disposal

When disposing LCD module, obey the local environmental regulations.